

633 ACCU-PRO AC/SC SPIN/RELIEF REEL GRINDER

STANDARD FEATURES ::

SPIN-GRIND AND PATENTED HANDS FREE AUTO-INDEX RELIEF GRIND CAPABILITY IN ONE SET-UP

COMPLETE SURROUND GUARDING WITH ELECTRICALLY INTER-LOCKED RETRACTABLE SAFETY GLASS DOORS AND REAR LIFT GATE

VARIABLE SPIN SPEED, TRAVERSE SPEED, RELIEF TORQUE

COUNTER-BALANCED SPIN DRIVE AND 8, 9, AND 11 SPLINE REEL DRIVE ADAPTERS

AUTOMATIC REEL POSITIONS USING THE ACCU-REEL SELECTOR, FRONT ROLLER CLAMP, AND CYLINDER HEIGHT STOP

VERTICAL AND HORIZONTAL ADJUSTER FOR PRECISE CARRIAGE POSITION AND TAPER REMOVAL

OPTIONAL EQUIPMENT ::

ACCU-TOUCH 3 CONTROL: AUTOMATION FOR SPIN AND RELIEF

ELECTRIC OVERHEAD HOIST FOR FRONT OR REAR LOAD

WORKSTATION TABLE-LIFT/PORTABLE WORKBENCH FOR REAR LOAD

INTERNAL VACUUM SYSTEM COLLECTS DUST AND KEEPS SHOP AREA CLEAN

BECAUSE FOLEY COMPANY IS CONTINUALLY IMPROVING ITS PRODUCTS, SPECIFICATIONS ARE SUBJECT TO CHANGE WITHOUT NOTICE.

WEIGHT :: 1530 lbs (693 kg)

DIMENSIONS ::

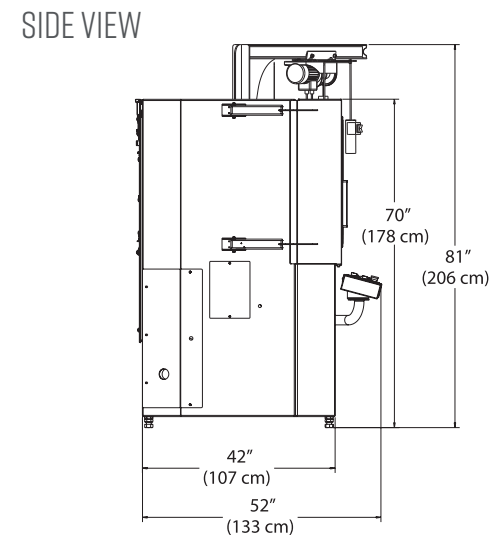
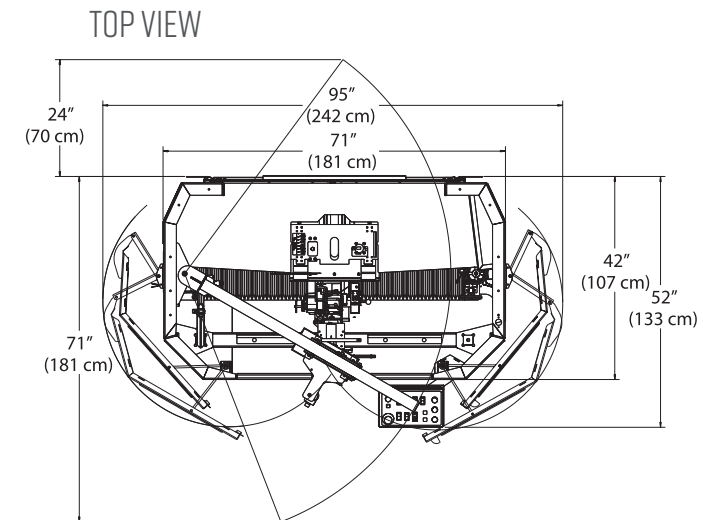

DISTRIBUTED BY:



FOLEY
COMPANY

PRECISION AT PLAY

P: 1.715.426.5151

TOLL FREE: 1.800.225.9810

FOLEYCO.COM

MADE IN THE USA

©2019 FOLEY COMPANY. LIT-2019-10002

FOLEY
COMPANY



633 ACCU-PRO AC/SC
SPIN/RELIEF REEL GRINDER

MANUAL OR AUTOMATIC SPIN/RELIEF GRINDER

633 ACCU-PRO AC/SC SPIN/RELIEF REEL GRINDER



REEL LIFTING
OPTIONS

**SIMPLICITY
+ QUALITY
AT ITS BEST**
WHETHER DOING QUICK
"TOUCH-UP" SPIN GRINDING
OR RETURNING THE REEL TO
SPECIFICATIONS, NOBODY
DOES IT BETTER THAN FOLEY.

1 633 SC CONTROLLER
633 AC CONTROLLER



2 ACCU-REEL SELECTOR



3 ELECTRONIC POSITIONING
DISPLAY



4 FRONT ROLLER CLAMP

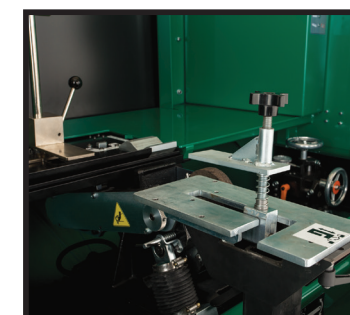

5 COUNTER-BALANCED SPIN DRIVE



6 ACCU-POSITIONING GAUGE



7 PATENTED GRINDING HEAD
& RELIEF ASSEMBLY



8 OPTIONAL ELECTRIC HOIST

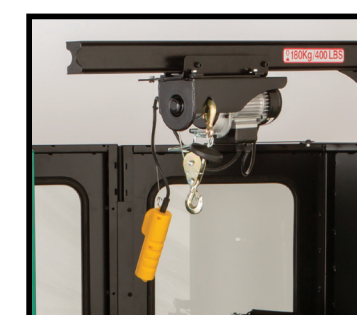

**SIMPLICITY
& QUALITY
AT ITS BEST**

LEARN MORE: FOLEYCO.COM

633 ACCU-PRO AC/SC OFFERS ::

AUTOMATED INFEEED GRIND CYCLES
FOR BOTH THE SPIN AND RELIEF GRIND PROCESS. (633AC)

SPIN GRIND IN MINUTES
LET THE ACCU-TOUCH 3 DO THE WORK WHILE YOU DO
SOMETHING ELSE. (633AC)

AUTO INDEX RELIEF
AUTOMATION OF INFEEEDS AND THE PATENTED AUTO-INDEX
PROVIDES PRODUCTIVITY AND CHOICE.

ONE STEP REEL PLACEMENT
TO AUTOMATICALLY LOCATE THE REEL FOR A FAST AND EASY SPIN OR
SPIN + RELIEF GRIND.

EASY TO USE CONTROLS
THE 633 SC USES A PRECISION PUSH-BUTTON TO IN-FEED THE
GRINDING HEAD WHILE IT AUTOMATICALLY TRAVERSES. THE 633 AC
AUTOMATES THE PROCESS TO AUTOMATICALLY IN-FEED THE GRINDING
HEAD AND STOP THE GRINDING PROCESS WHEN COMPLETED.